

Pre-assembled manifold with pressure gauge & auto air vent

Tio's premium 304 stainless-steel manifold is a pre-assembled unit for use within either underfloor heating systems or wall-hung radiator systems.

The unit is pre-assembled and complete with an auto air vent (AAV), 10 bar pressure gauge, flow meters with 0-5 l/m indicators and fill and drain valves.

Compatible with various pipe sizes up to 20mm. Integrated with filling and drain off valves to ease long term maintenance.



**Flow Meter
TIOSPA0018**



**Pin Valve Set
TIOSPA0003**



**Drain Valve
TIOSPA0004**



**Auto Air Vent
TIOSPA0004**



**Pressure Gauge
TIOSPA0004**

Tio's premium manifolds have a standard UK distance of 210mm between the flow and return bars. This makes the unit versatile with various mixing units. The unit has a spacing of 50mm between each port from the centre point advocating for various pipe sizes and materials to be installed.

For ease of installation, we recommend no larger than 20mm pipe to be installed with the Tio manifold connectors. The unit has 1" threaded inlets to house isolation valves and the bottom rail has a modulating pin that can be either, manually adjusted with the white adjusting caps, or to achieve electronic control, an actuator can be installed.

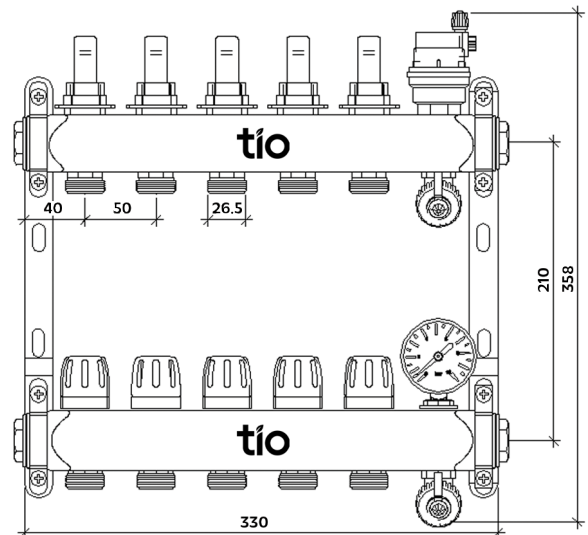

Product Code	Product Description	Gap Width
TIOMAN0002	2 Port Manifold with PG and AAV	180mm
TIOMAN0003	3 Port Manifold with PG and AAV	230mm
TIOMAN0004	4 Port Manifold with PG and AAV	280mm
TIOMAN0005	5 Port Manifold with PG and AAV	330mm
TIOMAN0006	6 Port Manifold with PG and AAV	380mm
TIOMAN0007	7 Port Manifold with PG and AAV	430mm
TIOMAN0008	8 Port Manifold with PG and AAV	480mm
TIOMAN0009	9 Port Manifold with PG and AAV	530mm
TIOMAN0010	10 Port Manifold with PG and AAV	580mm
TIOMAN0011	11 Port Manifold with PG and AAV	630mm
TIOMAN0012	12 Port Manifold with PG and AAV	680mm

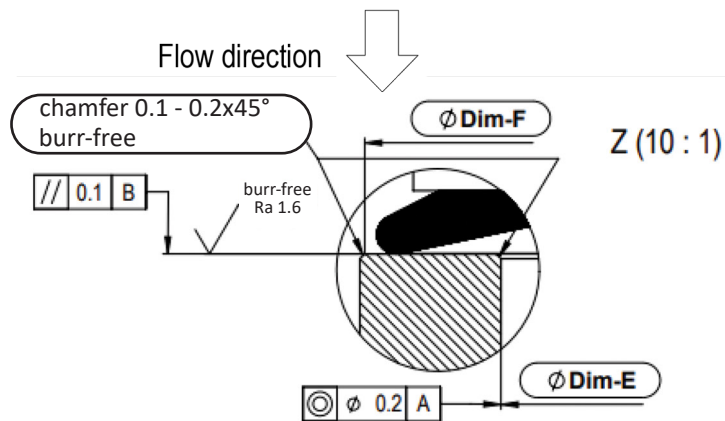
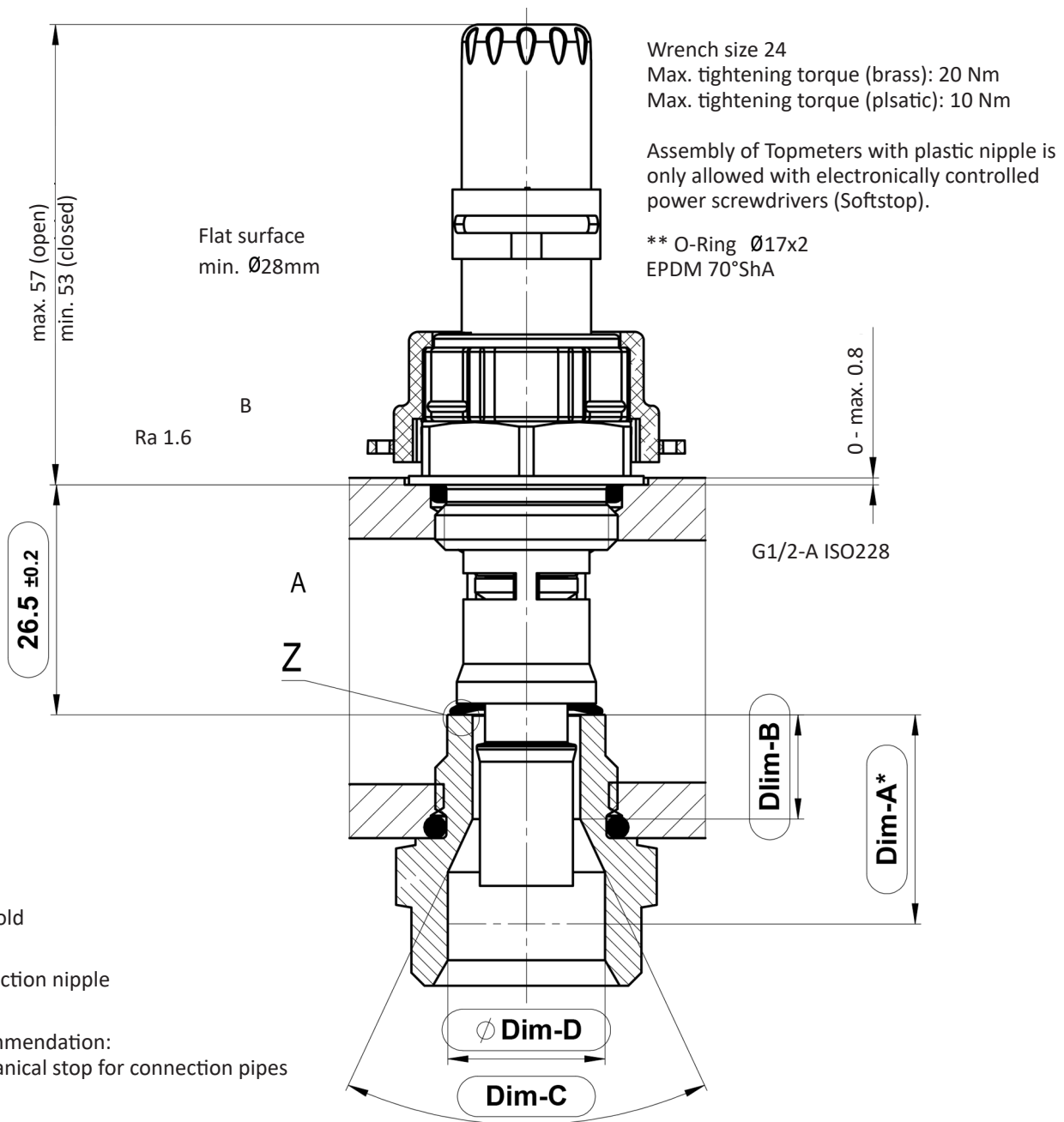

Filling

We recommend filling each circuit separately, opening the return isolation valves and double regulating valves each time and closing them again when the circuit is full as per the instructions below:

1. Isolate the manifold via the ball valves.
2. Connect the hose to the return manifold (the bottom manifold bar) via the drain point. The discharge hose should be run to a bucket or drainage point.
3. Connect mains pressure water to the flow manifold (the top manifold bar) via the fill point.
4. Close all of the return valves by turning the blue adjustable heads clockwise.
5. Open flow meter valve and the corresponding return isolation valves. Begin filling the first circuit.
6. Once the water flowing from the discharge hose is flowing smoothly, all air has been removed from the circuit.
7. Close this circuit and fill the next circuit following the same procedure.

Testing

1. Once filled, the system should be pressure tested in accordance with EN1264-4:2009 between 4-6 bar.
2. The system should be left under pressure whilst fixing a floor or laying the screed.

Commissioning

1. In order to commission the system, the heat source needs to be operating to deliver the required temperature of water to the manifold and the primary secondary pumps need to be operating.
2. To adjust the flow meters, follow the adjustment procedure above. The actual required flow will depend on the heat requirement of the room and the amount of pipe in the floor. Most modern buildings insulated to current building regulations will require around 50-60 W/m². As a general guide, we recommend that the following flow rates are set (when using 16mm pipe at 200mm centres):
3. Replace the red locking ring once the flow meters are set.
4. The underfloor heating pipework will not corrode in any way since it is plastic. However, it is recommended that a suitable inhibitor is added to avoid the corrosion of primary pipework, the heat source and any other towel rails or radiators on the system.
5. Initial setting of the thermostatic blending valve (after the initial system start-up/screed drying period) should provide the following temperatures: Screeded/dry screed board floors (35-45°C), Timber/floating floors (45-55°C) depending on design.

System Start Up

For screed floors, ensure a minimum of 21 days have elapsed since laying the concrete screed, or seven days if an anhydrite floor screed is utilised. Wooden floors can be switched on quite early, but should not be allowed to reach too high of a temperature too soon.

Wood being a natural material requires that both the floor and deck and joists must be treated with care until temperature and humidity have stabilised. Where water temperature controls are utilised, ensure they are set to aid gradual drying of the floor and structure.

System responses will be very slow on initial start-up. After the heating has been running for the recommended time at minimum setting (3 days for solid concrete floors and 1 day for wooden suspended floors), gradually raise the water temperature to the design setting for a further 4 days.

Once running normally, there should be a 7-8°C temperature drop across the circuits. Once all the actions are complete, turn down all thermostats so that the system stops. After it is determined that the thermostat is controlling the correct actuator, turn the thermostat down and repeat the procedure.

Additional Tio components included are an automatic air vent with 1/2 inch inlet and a drain/fill valve with a 1/2 inch inlet.

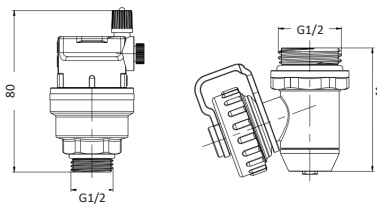

The Tio premium stainless steel manifold can be wall mounted by using the brackets provided. Suitable wall fixings will need to be assessed. All components are supplied with the box packaging unit.

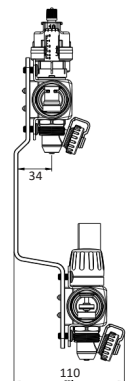

Flow & Pressure Adjustment

Flow and pressure loss in [mbar] and associated correlating [kPa] is indicated in the attached chart. The unit has the ability to adjust flow in accordance with professionally design project criteria.

The flow meter is adjusted using the anti-clockwise and clockwise turning mechanism to open and close the port and increase and reduce flow respectively.

