

Emmeti mixing unit and probe with Wilo Para 25/7 pump

Combining the Wilo Para 25/7 pump and a mixing valve with remote probe actuation to give a temperature range between 20°C - 70°C. Thus, making it suitable for screed drying purposes. It includes a throttle to increase Kv for larger systems. Includes a temperature gauge measuring the mixed flow temperature, manual air vent and bracket to support the weight of the pump.

- Connections - takeoffs G1" 1/2 - 130mm rotation
- Speed: 2580 - 470 RPM
- Maximum head: 7m
- Maximum flow rate 3.5 m³/h
- Maximum water temperature: 90°C
- Hz protection Class: IPX 4D
- Energy rating: A
- Energy consumption at 230v: 8.2 - 50W



Product Code	Product Description
TIOMIX0003	Emmeti mixing unit and probe with Wilo Para 25/7 pump

Maximum pressure	8 bar
Primary circuit maximum temperature	95°C
Thermostatic secondary range	20°C - 70°C
Mixing unit inlet size	G1" Female
Pressure drop	Kv 3

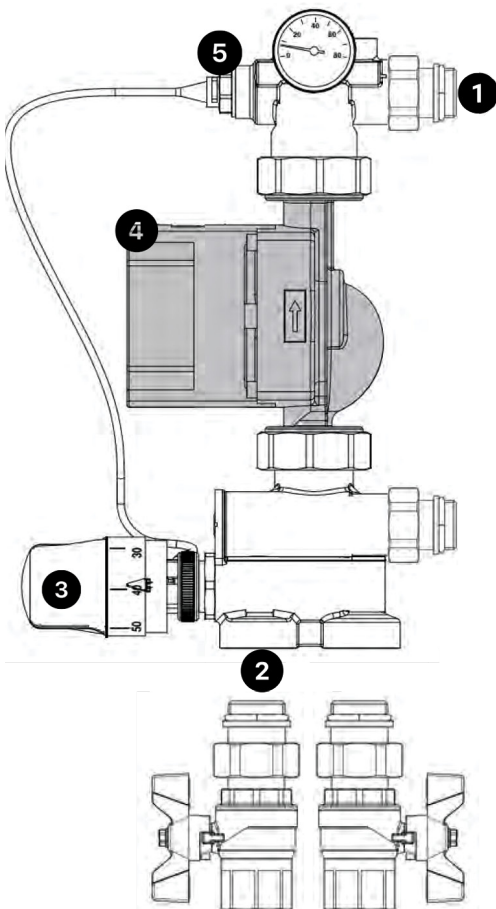

- 1 Connection point to manifold with 1¼" to 1"
- 2 1" Female threaded inlet
- 3 Thermostatic secondary regulation
- 4 A Rated Pump
- 5 Probed top elbow with gauge and AAV

Installation

Take the TIOMIX0003 unit out of the box, paying special attention and care to the gauge. Ensure the TIOMIX0003 is a correct fit for the manifold you will be using. The centres are set at 210mm from the outlet, centre to centre. The Tio Manifold is perfect fit for this. Other manifolds may not be the appropriate size.

With the manifold fit to a back board, marry up the mixing unit and insert the male adaptive nuts into the manifold. Please ensure the gasket has a full seal.

Then install 1" male valves into the base of the mixing unit. These valves will allow for isolation of flow and return pipes.

When all components are in place, using some mechanical assistance such as a wrench, we advise a further tightening of all valves and nuts, as this will fully seal the unit.

The thermostatic actuator (Fig 1.3) allows a manual secondary adjustment of the temperature. This is particularly good for screeding to allow a low curing at 20°C minimum temperature blend.

Located above the pin is a KV 1-5, the unit is set to 3 as this will allow for a suitable 12 port unit to be installed. Should you require an additional manifold this can be increased to 5.

WILO Para Circulator Technical Data

- Connections - takeoffs G1" 1/2 - 130mm Rotation
- Speed: 2580 - 470 RPM
- Maximum Head: 7m
- Maximum Flow Rate 3.5m³/h
- Maximum Water Temperature: 90°C
- Hz Protection Class: IPX 4D
- Insulation Class: F
- Energy Rating: A
- Energy Consumption at 230V: 8.3 - 50W

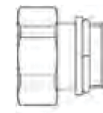

Fig 1.1 showing the captive nut to link the mixing unit to the manifold



Fig 1.2 showing M 1" Isolation Valves

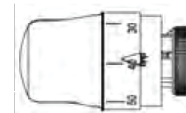

Fig 1.3 showing a thermostatic actuator

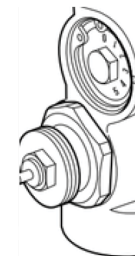

Fig 1.4 showing a KV adjustment



Warning

The floor-mounted system can be heated up only after the screeds curing (at least 28 days for cement screeds). Before laying the flooring, you need to start the system by setting the water temperature to 25°C for 3 days. Then, increase it by 5°C every 3 days until you reach 50°C and keep this temperature for at least 4 days.

